



Type 438

Safety Relief Valves
– spring loaded

US Units



Facts

LESER

The-Safety-Valve.com

Available designs

Type 438

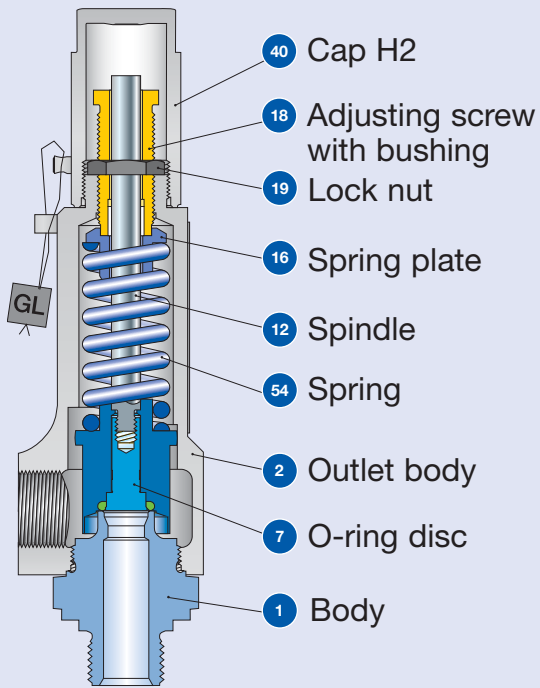

Conventional design
Threaded connection

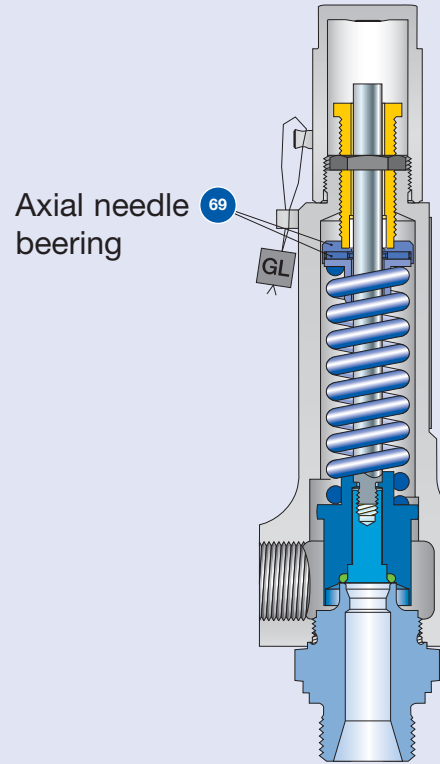

Long version
Threaded connection

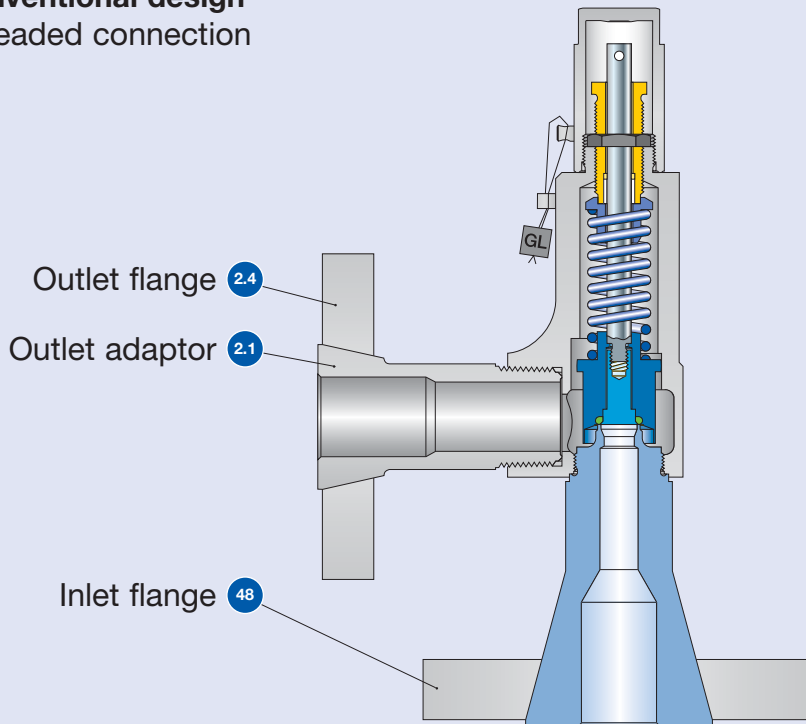

Conventional design
Flange connection

Available designs – materials

Materials			Type 4383	Type 4384
Item	Component	Remarks	Type 4383	Type 4384
1	Base / Inlet body	Threaded connection	1.4104 ¹⁾ , 1.4404 SA 479 430 ¹⁾ , SA 479 316L	1.4404 SA 479 316L
		Flange connection	1.4404 SA 479 316L	1.4404 SA 479 316L
		Long version	1.4104 ¹⁾ , 1.4404 SA 479 430 ¹⁾ , SA 479 316L	1.4404 SA 479 316L
2	Outlet body		1.4104 SA 479 430	1.4404 SA 479 316L
2.1	Outlet adaptor	Flange connection	1.4404 316L	1.4404 316L
2.4	Outlet flange	Flange connection	1.4404 316L	1.4404 316L
7	O-ring disc		1.4404 SA 479 316L	1.4404 SA 479 316L
7.4	Soft seal O-ring	“N”	NBR Nitrile-Butadiene	NBR Nitrile-Butadiene
		“K”	CR Chloroprene	CR Chloroprene
		“D”	EPDM Ethylen-Propylene-Diene	EPDM Ethylen-Propylene-Diene
		“L”	FKM Fluorocarbon	FKM Fluorocarbon
		“C”	FFKM Perfluor	FFKM Perfluor
12	Spindle		1.4021 420	1.4571 316Ti
		Long version	1.4571 316Ti	1.4571 316Ti
16	Spring plate		1.4104 Chrome steel	1.4404 316L
		Long version	1.4404 316L	1.4404 316L
18	Adjusting screw with bushing		1.4104 / PTFE Chrome steel / PTFE	1.4404 / PTFE 316L / PTFE
19	Lock nut		1.0718 Steel	1.4404 316L
40	Cap H2		1.0718 Steel	1.4404 316L
48	Inlet flange	Flange connection	1.4404 316L	1.4404 316L
54	Spring		1.4310 Stainless steel	1.4310 Stainless steel
69	Axial needle bearing	Long version	1.4404 316L	1.4404 316L

¹⁾ Only for male thread DIN ISO 228-1 G³/₈, G¹/₂, G³/₄ (Option codes V49, V54, V55).

Please notice:

- Modifications reserved by LESER.
- LESER can upgrade materials without notice.
- Every part can be replaced by other material acc. to customer specification.

How to order – Article numbers

Article numbers

		Conventional design	Long version
Actual Orifice diameter d_0 [mm]		10	10
Actual Orifice area A_0 [mm ²]		78.5	78.5
Actual Orifice diameter d_0 [inch]		0.394	0.394
Actual Orifice area A_0 [inch ²]		0.122	0.122
O-ring material		NBR "N" J30	NBR "N" J30
		CR "K" J21	CR "K" J21
		EPDM "D" J22	EPDM "D" J22
		FKM "L" J23	FKM "L" J23
		FFKM "C" J20	FFKM "C" J20
Base / Inlet body material: 1.4104 (430)			
H2	Art.-No. 4383.	2862	2872
H3	Art.-No. 4383. P_{max} = 16 bar_g	2863	-
H4	Art.-No. 4383.	2864	2874
p [bar _g]	S/G/L	5 – 93	93 – 180
p [psig]	S/G/L	72.5 – 1349	1349 – 2611
Base / Inlet body material: 1.4404 (316L)			
H2	Art.-No. 4384.	2982	2992
H4	Art.-No. 4384.	2984	2994
p [bar _g]	S/G/L	5 – 68	68 – 180
p [psig]	S/G/L	72.5 – 986	986 – 2611

Dimensions and weights – US Units

Threaded connections

	Size Outlet body	Conventional design			Long version		
		1/2"	3/4"	1"	1/2"	3/4"	1"
Actual Orifice diameter d_0 [inch]		0.394	0.394	0.394	0.394	0.394	0.394
Actual Orifice area A_0 [inch ²]		0.122	0.122	0.122	0.122	0.122	0.122
Weight [lbs]		2.6	3.5	3.5	3.1	4.6	4.6
Required installation diameter [inch]		2 ⁹ / ₁₆	3 ⁵ / ₃₂	3 ⁵ / ₃₂	2 ⁹ / ₁₆	3 ⁵ / ₃₂	3 ⁵ / ₃₂

Inlet thread "Female"

	Size outlet body	Conventional design			Long version			
		1/2"	3/4"	1"	1/2"	3/4"	1"	
Center to face [inch]								
DIN ISO 228-1	G	Inlet 1/2" a	1 ¹³ / ₁₆	1 ¹³ / ₁₆	1 ¹⁵ / ₁₆	1 ¹³ / ₁₆	1 ¹³ / ₁₆	1 ¹⁵ / ₁₆
			ISO 7-1/BS 21	Rc				
ASME B1.20.1	NPT	Inlet 3/4", 1" a	2 ⁷ / ₃₂	2 ⁷ / ₃₂	2 ⁵ / ₁₆	2 ⁷ / ₃₂	2 ⁷ / ₃₂	2 ⁵ / ₁₆
			Outlet b	1 ³ / ₁₆	1 ¹⁵ / ₃₂	1 ¹⁵ / ₃₂	1 ³ / ₁₆	1 ¹⁵ / ₃₂
Height [inch]								
		Inlet 1/2" H max.	8 ⁷ / ₃₂	8 ⁷ / ₃₂	8 ¹¹ / ₃₂	9 ¹ / ₁₆	9 ¹ / ₁₆	9 ³ / ₁₆
		Inlet 3/4", 1" H max.	8 ⁵ / ₈	8 ⁵ / ₈	8 ³ / ₄	9 ⁷ / ₁₆	9 ⁷ / ₁₆	9 ⁹ / ₁₆

Inlet thread "Male"

	Size outlet body	Conventional design			Long version					
		1/2"	3/4"	1"	1/2"	3/4"	1"			
Center to face [inch]										
DIN ISO 228-1	G	Inlet a	1 ⁵ / ₁₆	1 ⁵ / ₁₆	1 ¹³ / ₃₂	1 ⁵ / ₁₆	1 ⁵ / ₁₆	1 ¹³ / ₃₂		
			Outlet b	1 ³ / ₁₆	1 ¹⁵ / ₃₂	1 ¹⁵ / ₃₂	1 ³ / ₁₆	1 ¹⁵ / ₃₂	1 ¹⁵ / ₃₂	
ISO 7-1/BS 21	R	Inlet a	1 ⁷ / ₃₂	1 ⁷ / ₃₂	1 ¹¹ / ₃₂	1 ⁷ / ₃₂	1 ⁷ / ₃₂	1 ¹¹ / ₃₂		
			ASME B1.20.1	NPT						
		Outlet b	1 ³ / ₁₆	1 ¹⁵ / ₃₂	1 ¹⁵ / ₃₂	1 ³ / ₁₆	1 ¹⁵ / ₃₂	1 ¹⁵ / ₃₂		
Height [inch]										
	Size inlet thread	Conventional design				Long version				
		3/8"	1/2"	3/4"	1"	3/8"	1/2"	3/4"	1"	
DIN ISO 228-1	G	H max.	8 ³ / ₁₆	8 ¹ / ₄	8 ¹¹ / ₃₂	8 ¹⁷ / ₃₂	9	9 ³ / ₃₂	9 ⁵ / ₃₂	9 ³ / ₈
ISO 7-1/BS 21	R	H max.	–	8 ³ / ₈	8 ¹³ / ₃₂	8 ²¹ / ₃₂	–	9 ⁷ / ₃₂	9 ¹ / ₄	9 ¹⁵ / ₃₂
ASME B1.20.1	NPT	H max.	–	8 ¹ / ₂	8 ¹ / ₂	8 ¹³ / ₁₆	–	9 ⁵ / ₁₆	9 ⁵ / ₁₆	9 ²¹ / ₃₂
Length of screwed end "c" [inch]										
	Size inlet thread	3/8"	1/2"	3/4"	1"					
DIN ISO 228-1	G	1 ⁵ / ₃₂	9 ¹ / ₁₆	5 ¹ / ₈	2 ³ / ₃₂					
ISO 7-1/BS 21	R	–	3 ¹ / ₄	2 ⁵ / ₃₂	2 ⁹ / ₃₂					
ASME B1.20.1	NPT	–	7 ¹ / ₈	7 ¹ / ₈	1 ¹ / ₁₆					

Available threaded connections refer to page 04/04.

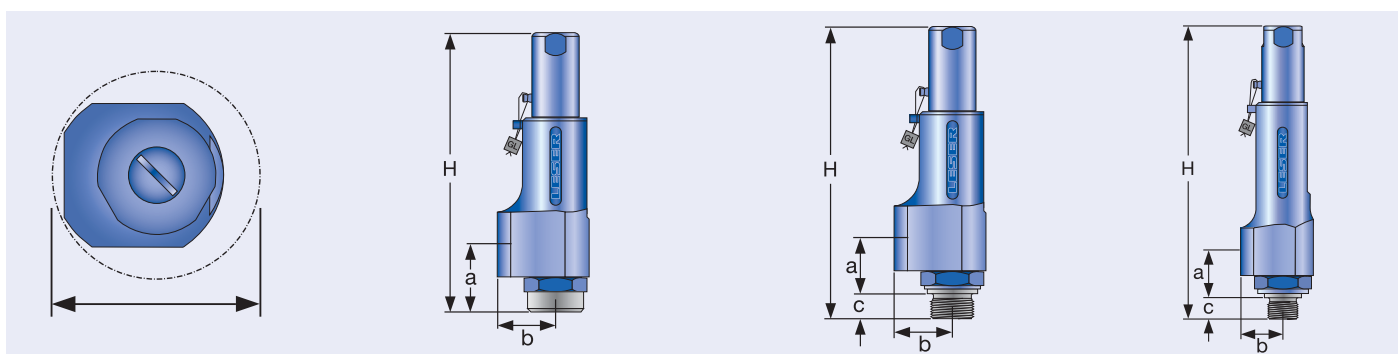

Required installation diameter

Conventional design – Female thread

Conventional design – Male thread

Long version – male thread

Dimensions and weights – US Units

Flanged connection

		Conventional design		Long version	
Actual Orifice diameter d_0 [inch]		0.394		0.394	
Actual Orifice area A_0 [inch ²]		0.122		0.122	
DIN EN 1092-1 (Available flange sizes refer to page 04/05)					
Flange rating PN 40					
Center to face	[inch]	Inlet a	$3^{15}/_{16}$		$3^{15}/_{16}$
		Outlet b	$3^{15}/_{16}$		$3^{15}/_{16}$
Height	[inch]	H max.	$10^{11}/_{32}$		$10^3/_{16}$
Flange rating \geq PN 160					
Center to face	[inch]	Inlet a	$4^1/_{16}$		$4^1/_{16}$
		Outlet b	$3^{15}/_{16}$		$3^{15}/_{16}$
Height	[inch]	H max.	$10^{15}/_{32}$		$11^5/_{16}$
ASME B 16.5 (Available flange sizes refer to page 04/05)					
Flange rating class 150					
Center to face	[inch]	Inlet a	$3^{15}/_{16}$		$3^{15}/_{16}$
		Outlet b	$3^{15}/_{16}$		$3^{15}/_{16}$
Height	[inch]	H max.	$10^{11}/_{32}$		$11^3/_{16}$
Flange rating class \geq 300					
Center to face	[inch]	Inlet a	$4^1/_{16}$		$4^1/_{16}$
		Outlet b	$3^{15}/_{16}$		$3^{15}/_{16}$
Height	[inch]	H max.	$10^{15}/_{32}$		$11^5/_{16}$
Weight					
For the calculation of the total weight please use the Formular: $W_T = W_N + W_F$ (Inlet) + W_F (Outlet)					
Weight net	[lbs]	W_N	5.3		6.2
(without inlet and outlet flange)					

Flange dimensions and availability

		DIN EN 1092-1 / Flange rating PN						ASME B16.5 / Flange rating class							
		Size	40	100	160	250	320	400	Size	150	300	600	900	1500	2500
		DN 15							NPS $1/2$"						
Flange thickness	[inch] s		$2^3/_{32}$	–	$7/8$	$1^3/_{32}$	$1^3/_{32}$	$1^6/_{32}$		$9/_{16}$	$2^3/_{32}$	$2^3/_{32}$	$1^1/_{32}$	$1^1/_{32}$	$1^6/_{32}$
Weight slip on flange	[lbs] W_F		1.8	–	2.6	5.5	5.5	7.9		1.3	2.0	2.0	4.6	4.6	6.6
		DN 20							NPS $3/4$"						
Flange thickness	[inch] s		$2^5/_{32}$	$2^8/_{32}$	–	–	–	–		$1^9/_{32}$	$2^3/_{32}$	$2^3/_{32}$	1	1	$1^8/_{32}$
Weight slip on flange	[lbs] W_F		2.4	2.9	–	–	–	–		1.8	3.1	3.1	5.0	5.0	7.7
		DN 25							NPS 1"						
Flange thickness	[inch] s		$7/8$	–	$1^1/_{32}$	$1^6/_{32}$	$1^13/_{32}$	$1^18/_{32}$		$2^1/_{32}$	$2^7/_{32}$	$2^7/_{32}$	$1^9/_{32}$	$1^9/_{32}$	$1^18/_{32}$
Weight slip on flange	[lbs] W_F		2.9	–	5.7	7.7	11.0	16.5		2.2	4.6	4.6	9.0	9.0	11.2

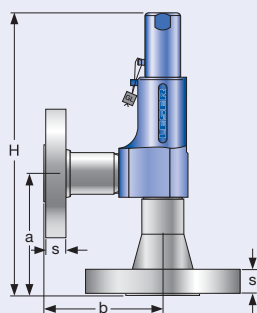

Conventional design

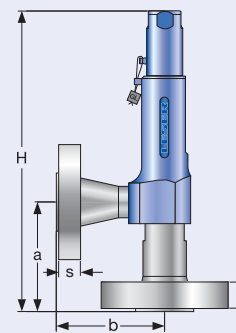

Long version

Pressure temperature ratings

Metric Units

		Conventional design				Long version			
Actual Orifice diameter d_0 [mm]		10				10			
Actual Orifice Area A_0 [mm ²]		78.5				78.5			
Body material: 1.4104 (430)									
Base / Inlet Body	Connection size	3/8"	1/2"	3/4"	1"	3/8"	1/2"	3/4"	1"
	Pressure rating	PN 320				PN 320			
Outlet body	Pressure rating	PN 160				PN 160			
Minimum set pressure	p [bar _g] S/G/L	5				93			
Maximum set pressure	p [bar _g] S/G/L	16 [only H3] 93				180			
Temperature	min [°C]	-10				-10			
acc. to DIN EN	max [°C]	+150				+150			
Temperature	min [°C]	-29				-29			
acc. to ASME	max [°C]	+150				+150			
Body material: 1.4404 (316L)									
Base / Inlet Body	Connection size	3/8"	1/2"	3/4"	1"	3/8"	1/2"	3/4"	1"
	Pressure rating	PN 320				PN 320			
Outlet body	Pressure rating	PN 160				PN 160			
Minimum set pressure	p [bar _g] S/G/L	5				68			
Maximum set pressure	p [bar _g] S/G/L	68				180			
Temperature	min [°C]	-45				-45			
acc. to DIN EN	max [°C]	+150				+150			
Temperature	min [°C]	-45				-45			
acc. to ASME	max [°C]	+150				+150			

US Units

		Standard				Long version			
Actual Orifice diameter d_0 [inch]		0.394				0.394			
Actual Orifice area A_0 [inch ²]		0.122				0.122			
Body material: 1.4104 (430)									
Base / Inlet Body	Connection size	3/8"	1/2"	3/4"	1"	3/8"	1/2"	3/4"	1"
Minimum set pressure	p [psig] S/G/L	72.5				1349			
Maximum set pressure	p [psig] S/G/L	232 [only H3] 1349				2611			
Temperature	min [°F]	+14				+14			
acc. to DIN EN	max [°F]	+302				+302			
Temperature	min [°F]	-20				-20			
acc. to ASME	max [°F]	+302				+302			
Body material: 1.4404 (316L)									
Base / Inlet Body	Connection size	3/8"	1/2"	3/4"	1"	3/8"	1/2"	3/4"	1"
Minimum set pressure	p [psig] S/G/L	72.5				986			
Maximum set pressure	p [psig] S/G/L	986				2611			
Temperature	min [°F]	-49				-49			
acc. to DIN EN	max [°F]	+302				+302			
Temperature	min [°F]	-49				-49			
acc. to ASME	max [°F]	+302				+302			

The temperature is limited by soft seal material. The stated values are valid for EPDM.

Available Options

Type 438

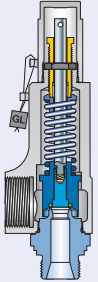
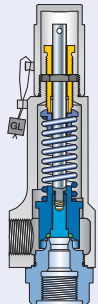
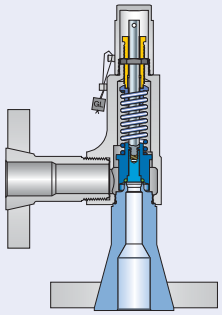
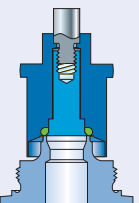
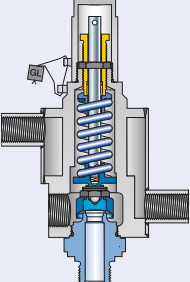
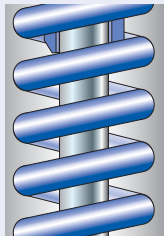
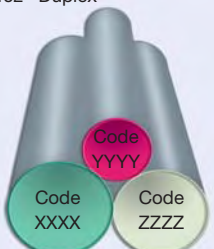
<p>Male thread</p> 	<p>Female thread</p> 	<p>Flanged version</p> 	
<p>Soft seal o-ring disc</p> <p>J30: NBR "N" J21: CR "K" J22: EPDM "D" J23: FKM "L" J20: FFKM "C"</p> 			
<p>Heating jacket H29</p> 	<p>Test gag J70: H2</p>	<p>INCONEL X-750 spring X08</p> 	
<p>Special material</p> <p>2.4610 Hastelloy® C4 2.4360 Monel® 400 1.4462 Duplex</p> 			

Application range of conventional design and long version

Application range

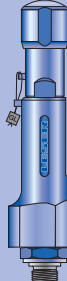

Type 438

Type 4383

Conventional design		Long version	
S/G/L		S/G/L	
	Act. Orifice diameter	d_0 [mm]	10
		[inch]	0.394
	Act. Orifice area	A_0 [mm ²]	78.5
		[inch ²]	0.122
Components		Materials	
Base / Inlet Body		1.4104 SA 479 430	
Disc		1.4404 SA 479 316L	
			
			Act. Orifice diameter
			[inch]
		Act. Orifice area	A_0 [mm ²]
			[inch ²]
		Components	
		Materials	
		Base / Inlet Body	1.4104 SA 479 430
		Disc	1.4404 SA 479 316L
0	986	1349	2611
0	68	93	180

Set pressure
p [psig]

Type 4384

Conventional design		Long version	
S/G/L		S/G/L	
	Act. Orifice diameter	d_0 [mm]	10
		[inch]	0.394
	Act. Orifice area	A_0 [mm ²]	78.5
		[inch ²]	0.122
Components		Materials	
Base / Inlet Body		1.4404 SA 479 316L	
O-ring disc		1.4404 SA 479 316L	
			
			Act. Orifice diameter
			[inch]
		Act. Orifice area	A_0 [mm ²]
			[inch ²]
		Components	
		Materials	
		Base / Inlet Body	1.4404 SA 479 316L
		O-ring disc	1.4404 SA 479 316L

Set pressure
p [bar]

Available connections

For dimensions and weights refer to:

Type 437 – page 01/08 + 01/10

Type 438 – page 02/08 + 02/10

Type 439 – page 03/08 + 03/10

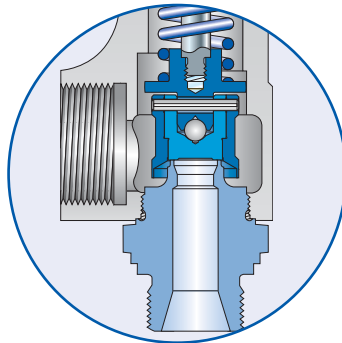

Male thread

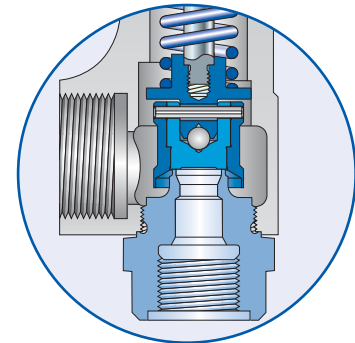

Female thread

Threaded connections

	Valve size	d ₀ 6 mm		d ₀ 10 mm	
		Inlet	Outlet	Inlet	Outlet
		Option code	Option code	Option code	Option code
Male thread DIN ISO 228-1					
G	3/8"	V49	–	V49	–
	1/2"	V54	–	V54	–
	3/4"	V55	–	V55	–
	1"	V56	–	V56	–
Female thread DIN ISO 228-1					
G	1/2"	V50	V65	V50	V65
	3/4"	V51	V76	V51	V76
	1"	V52	V66	V52	V66
Male thread DIN ISO 7- 1 / BS 21					
R/BSPT	1/2"	V30	–	V30	–
	3/4"	V31	–	V31	–
	1"	V32	–	V32	–
Female thread DIN ISO 7- 1 / BS 21					
Rc/BSPT	1/2"	V38	V34	V38	V34
	3/4"	V39	V35	V39	V35
	1"	V40	V36	V40	V36
Male thread ANSI / ASME B1.20.1					
NPT	1/2"	V61	–	V61	–
	3/4"	V62	–	V62	–
	1"	V63	–	V63	–
Female thread ANSI / ASME B1.20.1					
NPT	1/2"	V58	V70	V58	V70
	3/4"	V59	V77	V59	V77
	1"	V60	V71	V60	V71

Flanged and threaded connections can be combined.

Threads according to other standards are available.

Please specify in writing (diameter, pressure rating, standard).

Available connections

For dimensions and weights refer to:
 Type 437 – page 01/09 + 01/11
 Type 438 – page 02/09 + 02/11
 Type 439 – page 03/09 + 03/11

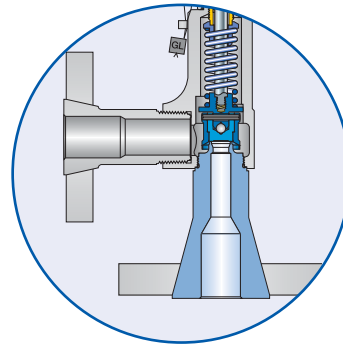

Flanged version

Flanged connections					
Valve size	Pressure rating	d ₀ 6 mm		d ₀ 10 mm	
DIN EN 1092-1 (PN > 100: DIN 2501)					
DN	PN	Option code		Option code	
		Inlet	Outlet	Inlet	Outlet
15	40		I40	I21	I40
	160		I41	I22	I41
	250	I23	I42	I23	I42
	320	I24	–	I24	–
	400	I25	–	I25	–
20	40	I26	I43	I26	I43
	100	I27	I44	I27	I44
25	40		I46	I31	I46
	160		I47	I32	I47
	250	I33	I48	I33	I48
	320	I34	–	I34	–
	400	I35	–	I35	–
ANSI/ASME B16.5					
NPS	CL	Option code		Option code	
		Inlet	Outlet	Inlet	Outlet
1/2"	150		V24	V01	V24
	300		V13	V02	V13
	600		V13	V02	V13
	900	V03	V14	V03	V14
	1500	V03	–	V03	–
	2500	V04	–	V04	–
3/4"	150		V15	V05	V15
	300		V16	V06	V16
	600		V16	V06	V16
	900	V07	V17	V07	V17
	1500	V07	–	V07	–
	2500	V08	–	V08	–
1"	150		V18	V09	V18
	300		V19	V10	V19
	600		V19	V10	V19
	900	V11	V20	V11	V20
	1500	V11	–	V11	–
	2500	V12	–	V12	–

Flanged and threaded connections can be combined.
 Threads according to other standards are available.
 Please specify in writing (diameter, pressure rating, standard).